



GNE module level optimization and monitoring system

Installation User Manual

(Honeybee350/400, Honeybee700/800, Scouter450 , Swarm, Beehive)

Jiangsu GNE New Energy Technology Co., Ltd.

Tel : +86 519 8728 1798

Email : service@gnetek.com | Web : www.gnetek.com

Add.: 1F/B, No.218 Hongkou Road, Liyang City, Jiangsu 213300, CHINA

Notice

- ◆ This user manual is used to install and maintain GNE power optimizer models Honeybee 350/400, Honeybee 700/800, PV monitor model Scouter350/450 and data processing devices.
- ◆ No permission to disassemble and repair the products to ensure the safety of personnel. For services, please look for trained or qualified professionals.
- ◆ Before installing and using the power optimizers, please familiarize yourself with all the tips and warnings on the products, as well as the safety instructions and other applicable safety guidelines in the inverter manual and the PV module installation instructions.
- ◆ To reduce the risk of fire and electric shock, install the power optimizers in strict accordance with local electrical standards and codes.
- ◆ Installation must be performed by a trained professional. GNE is not liable for any loss or damage caused by improper operation, discomfort or misuse of these products.
- ◆ Before installing the optimization and monitoring products, please remove all metal accessories that you wear to reduce the risk of touching live circuits. It is strictly forbidden to install and debug in bad weather.
- ◆ Do not operate if the GNE products can be physically damaged. Check existing cables and connectors to ensure they are in good condition and status. Do not operate the cables and connectors of GNE products if they are damaged or unqualified.
- ◆ Do not connect or disconnect the GNE power optimizers and monitoring products under load. There is also a risk of electric shock when shutting down the inverter or the GNE products. After disconnecting all power supplies, the capacitor inside the inverter can continue to charge for a few minutes. Before measuring the line, first measure the voltage at the inverter and confirm that the capacitor is no longer charged.
- ◆ Before the GNE customer service personnel provide services, please make sure that the data aggregation device Beehive is powered on and the internet is fine, and optimizers work in power-on status, then check the current, voltage and power of the PV series.

Installation Steps:

1. Smart PV diagram (Apidae)

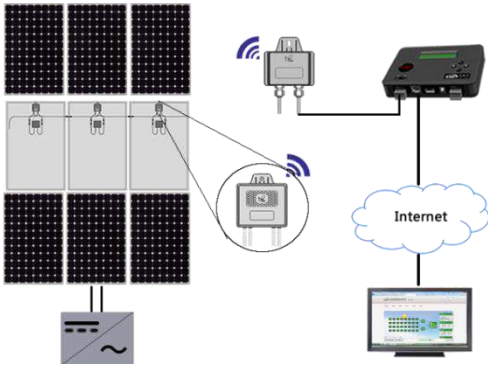

2. Register MACID of GNE models



3. Installation of optimizers or PV monitors

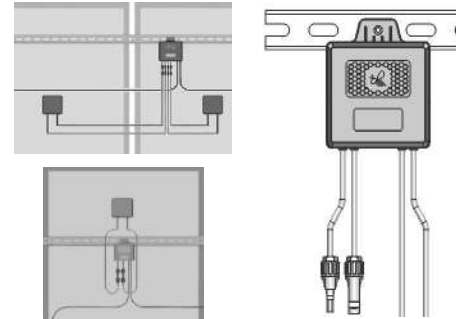

4. Installation of data acquisition unit (Swarm)



5. Connection to Swarm and Beehive



6. Installation of data aggregation device (Beehive)

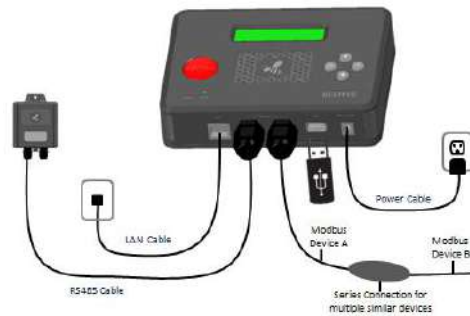

7. Setup in data cloud center (Honeypot)



8. Appendix - Product Specification



1. Smart PV Diagram(Apidae)

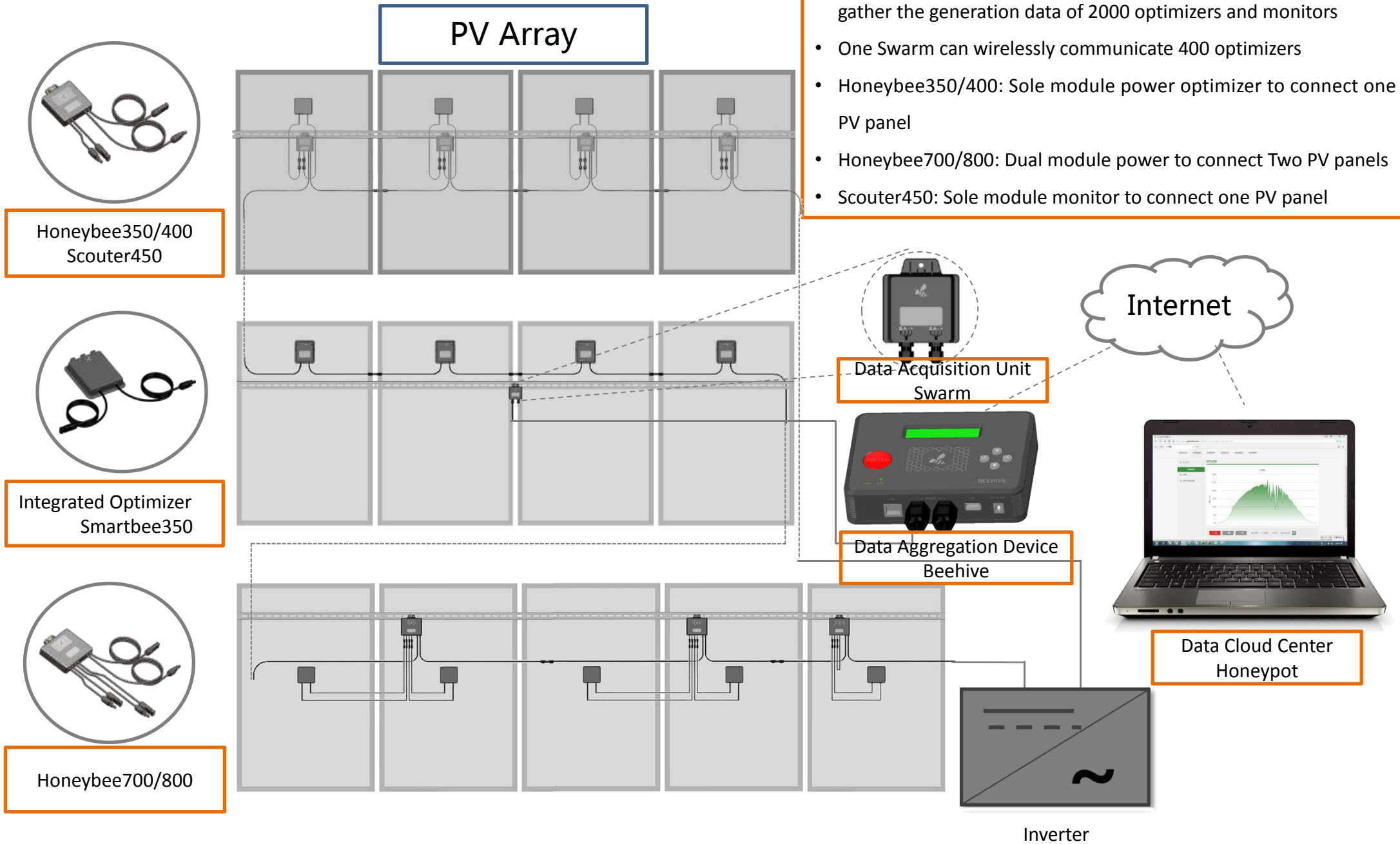

2. Register MACID of GNE models

- ①. Plan the installation location of each power optimizer or PV module monitor

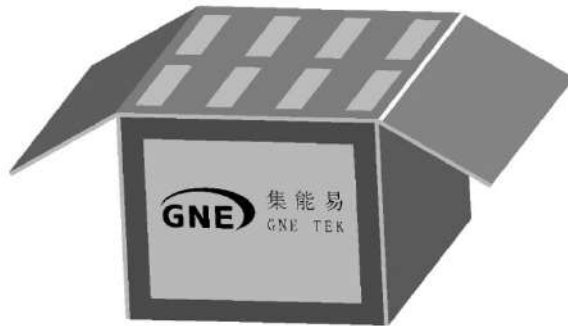

- ②. Take the power optimizer or PV module monitor and write down the 8-digit MACID number on the plant map, or string list, or construction drawing. And write down the 8-digit MACID number of Swarm and Beehive.

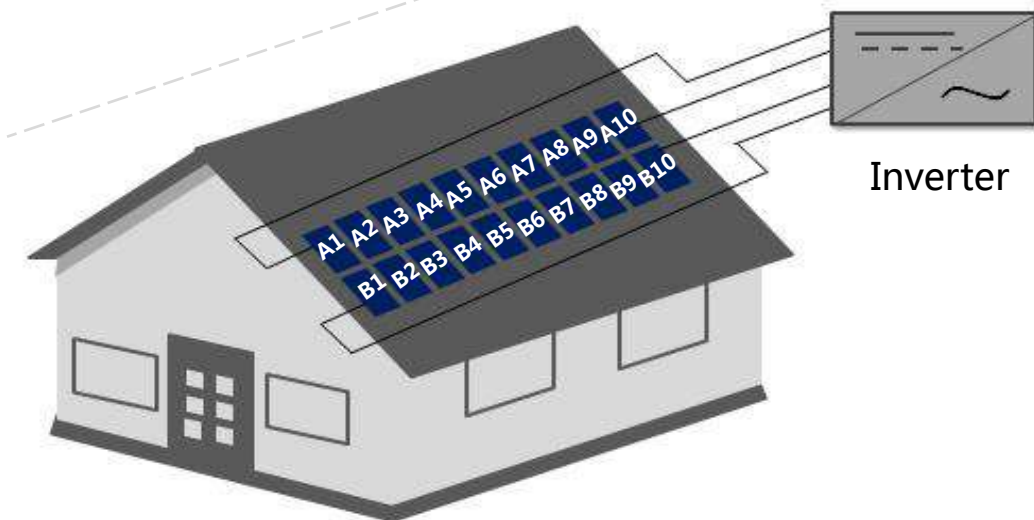
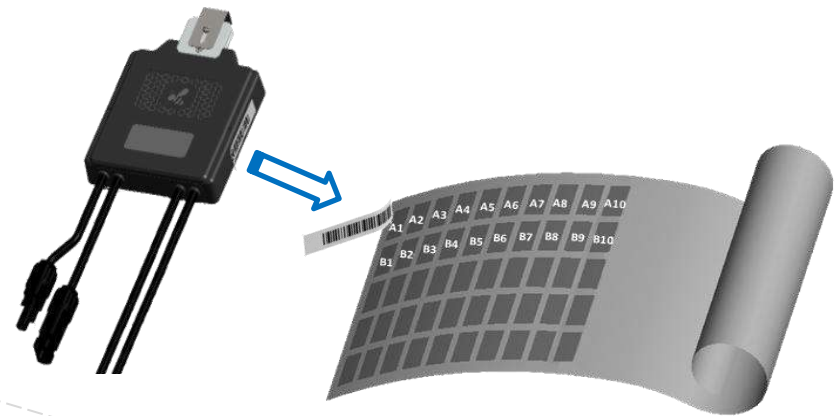

- ③. The installation position of the power optimizers or the PV module monitors should accord to the previously recorded MACID order.

3. Installation of optimizers or PV monitors

➤ Precautions before installation

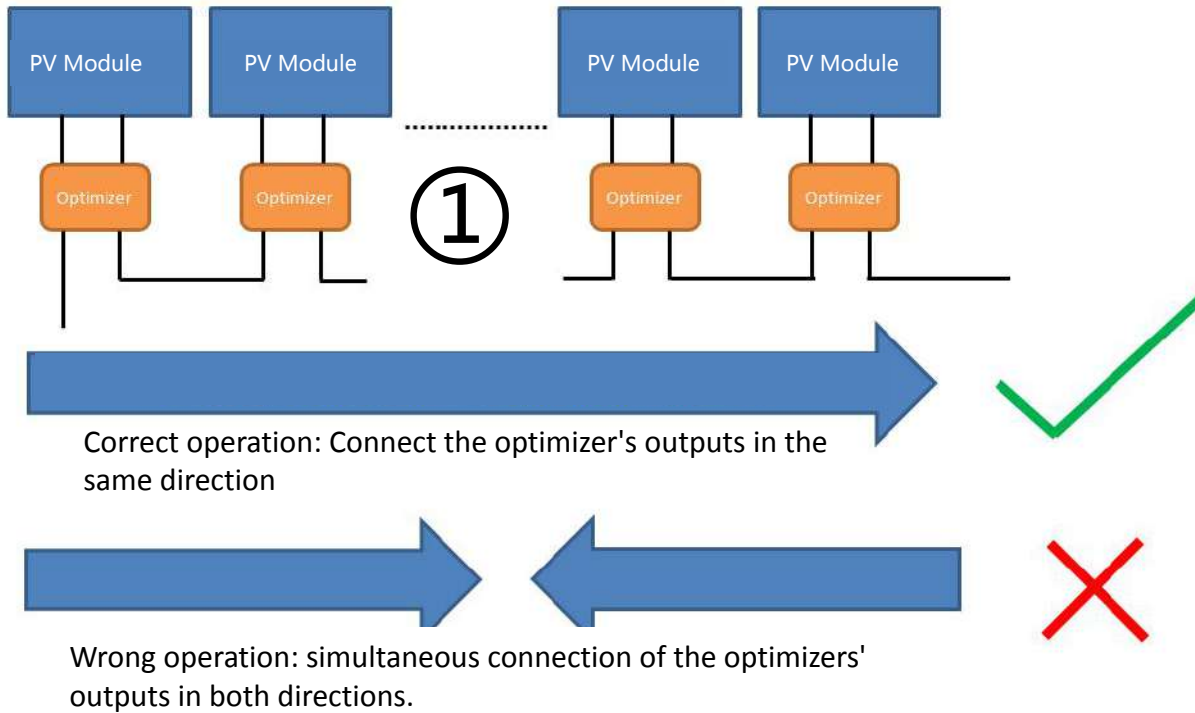

Description: When all the inputs of the optimizers are connected to the output of the PV junction boxes, the outputs of the optimizers are connected in series.

Correct operation: Connect the outputs of the optimizers in the same direction to ensure that the last two ends of the string are the positive and negative two-pole interfaces, not the same-pole interface (as shown in Figure 2).

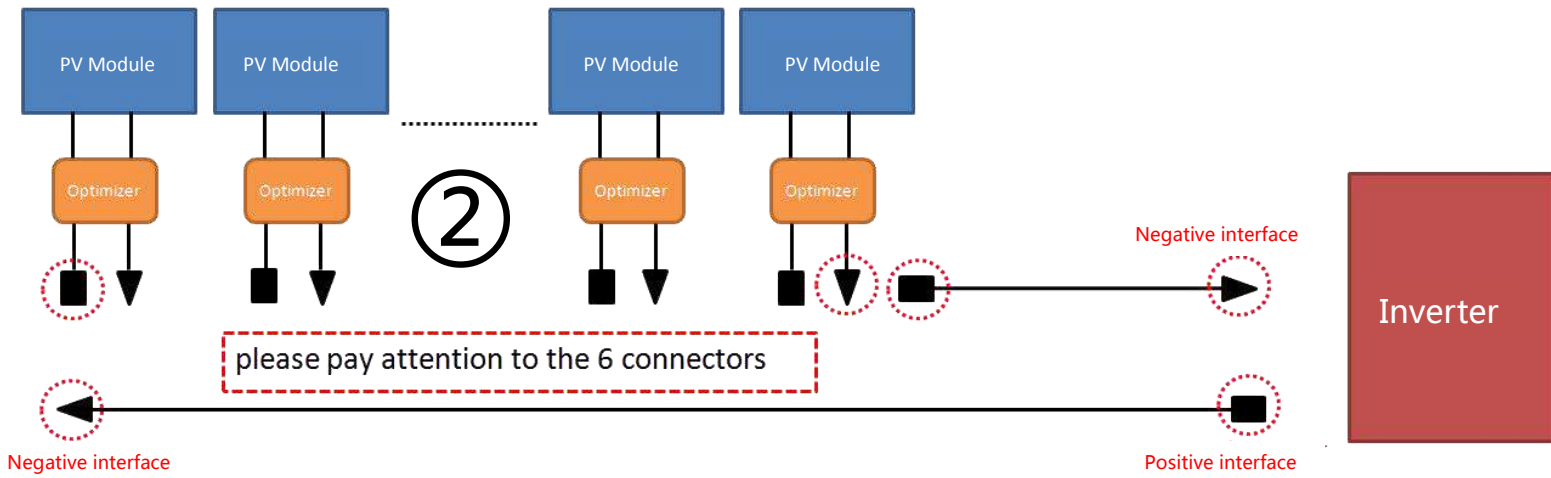

3. Installation of optimizers or PV monitors

①. Record the product MACID numbers of the optimizers or PV monitor on the system form or power station map or construction drawing to establish a power station in cludy center for tracking the operation status of each panel even the whole PV station.

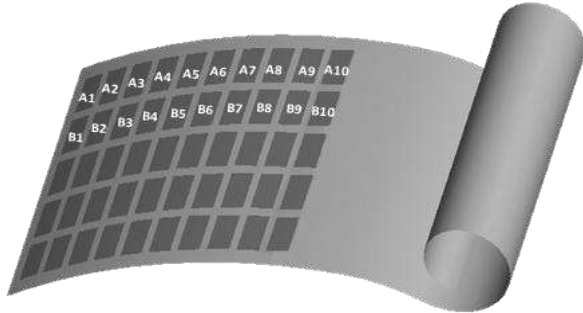

②. Use a screw or cable tie to position the optimizer or PV monitor one by one according to the registered MACID number position, and fix it on the bracket or panel frame. If the bracket has no mounting holes, it can be drilled and mounted with a hole size of 6mm.

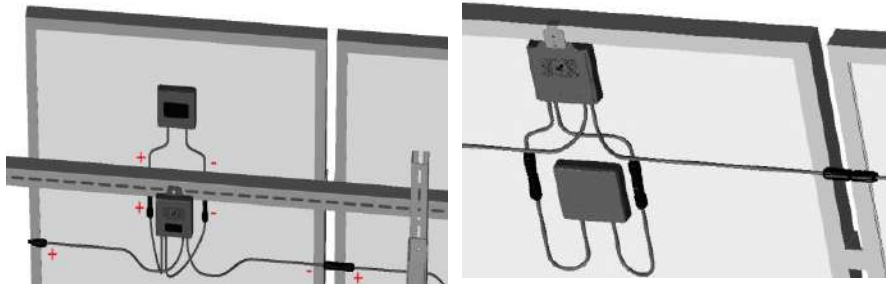

Remarks:

When connecting the dual module optimizer Honeybee700/800 to one PV panel, one pair of the input cables of the optimizer are connected the output ends of the PV module, and the other pair is directly docked.

③. The shorter pair of cables of the power optimizer or the PV monitor are the input terminals, and the longer pair of cables are the output terminals for the power optimizer or the PV monitor to be connected in series and finally connected to the inverter or the combiner box.

Cabling sequence: firstly connect all the input cables of the optimizers to the output cables of the PV junction box, then connect the output cables of all the optimizers in series (please refer to the previous page for notes)



4. Installation of data acquisition unit (Swarm)

①. Swarm is mounted on the bracket at the center of the PV module array and can be fixed with cable tie or a screw of diameter 6mm.

②. If you need to connect more Swarms, please connect them with RS485 cable.

Swarm cascade table:

Swarm	Cascade	Swarm
RS485 Terminal		RS485 Terminal
485B	↔	485B
485A	↔	485A
GND	↔	GND
12V	↔	12V

Note:
The data transmission between the Swarm and the power optimizers is wireless, and the effective communication distance is 50 meters.

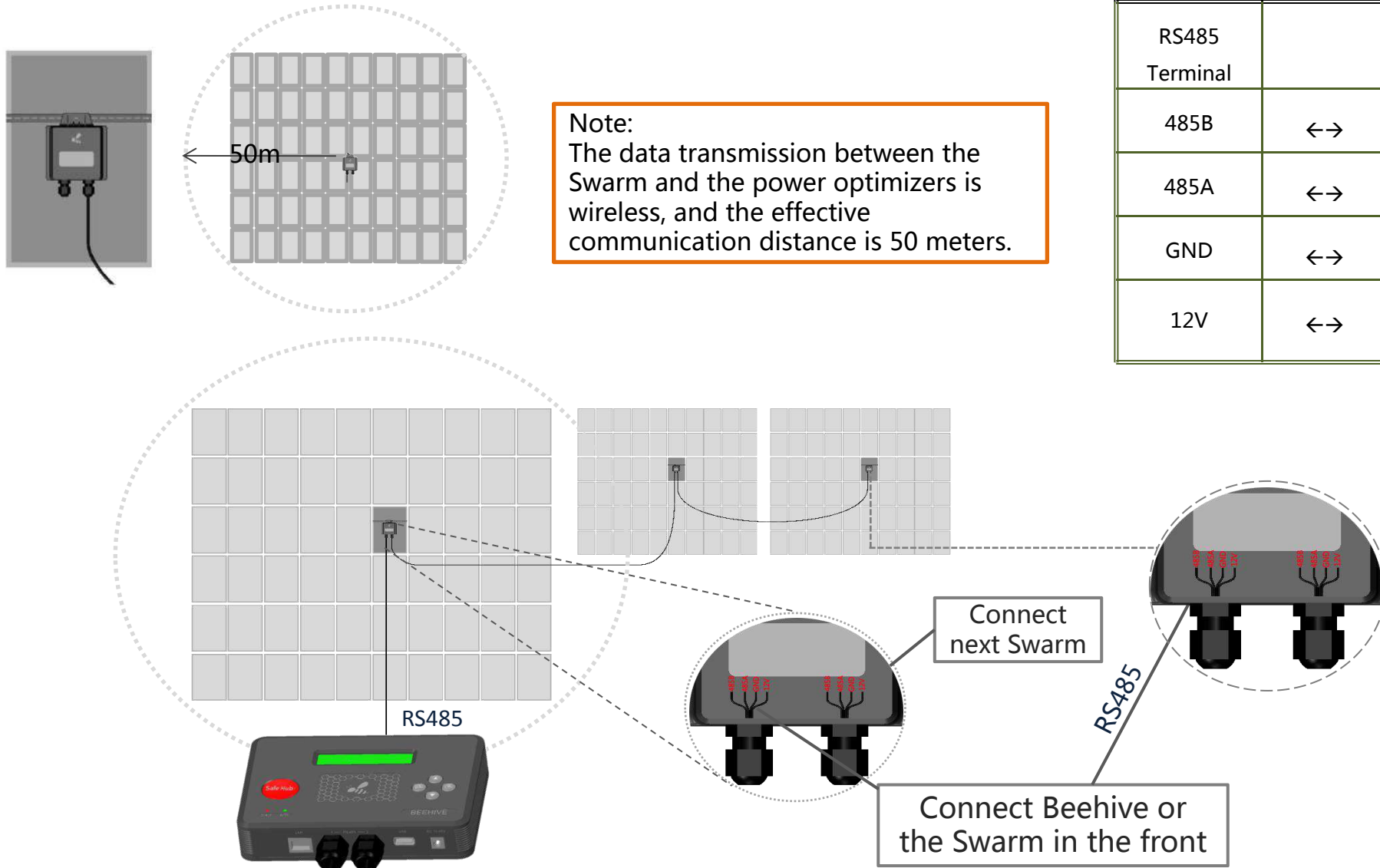

5. Connection to Swarm and Beehive

- ① Determine where the Beehive is installed and the length of RS485 cable from the Beehive to the Swarm
- ② Open the back covers of the Beehive to the Swarm
- ③ Connect the 485 cable to the RS485 port numbered 1 on the Beehive (refer to the right table for the wiring connection table) and tighten it with a flat head screwdriver.
- ④ Connect the other end of the 485 cable to any one RS485 interface of the Swarm, and the wiring order of the four color wires of the RS485 in the Swarm and the Beehive are consistent. **Note:** Any error in the connection order would cause damage to the Swarm or the Beehive.
- ⑤ Tighten the screws on the back cover of the Swarm and the Beehive with a cross screwdriver.

The wiring connection table of Swarm and Beehive

Swarm	Cascade	Swarm		Beehive			A third device
RS485 Terminal		RS485 Terminal		RS485 Terminal 1	RS485 Terminal 2		RS485 Terminal
485B	↔	485B	↔	485B	485B	↔	485B
485A	↔	485A	↔	485A	485A	↔	485A
GND	↔	GND	↔	GND	GND	↔	GND
12V	↔	12V	↔	VCC	VCC-USER		



6. Installation of data aggregation device (Beehive)

Notes for Operation:

1. The protection grade of the Beehive is IP20 and needs to be installed indoors. If it needs to be installed outdoors, please add a waterproof box.
2. Connect power, ethernet cable or third-party device to the corresponding terminals.
3. Test whether the Swarm and the network cable work normally (select "FIND 485" in the menu of the Beehive, press "OK" , then the connection number of the 485 devices will be displayed)

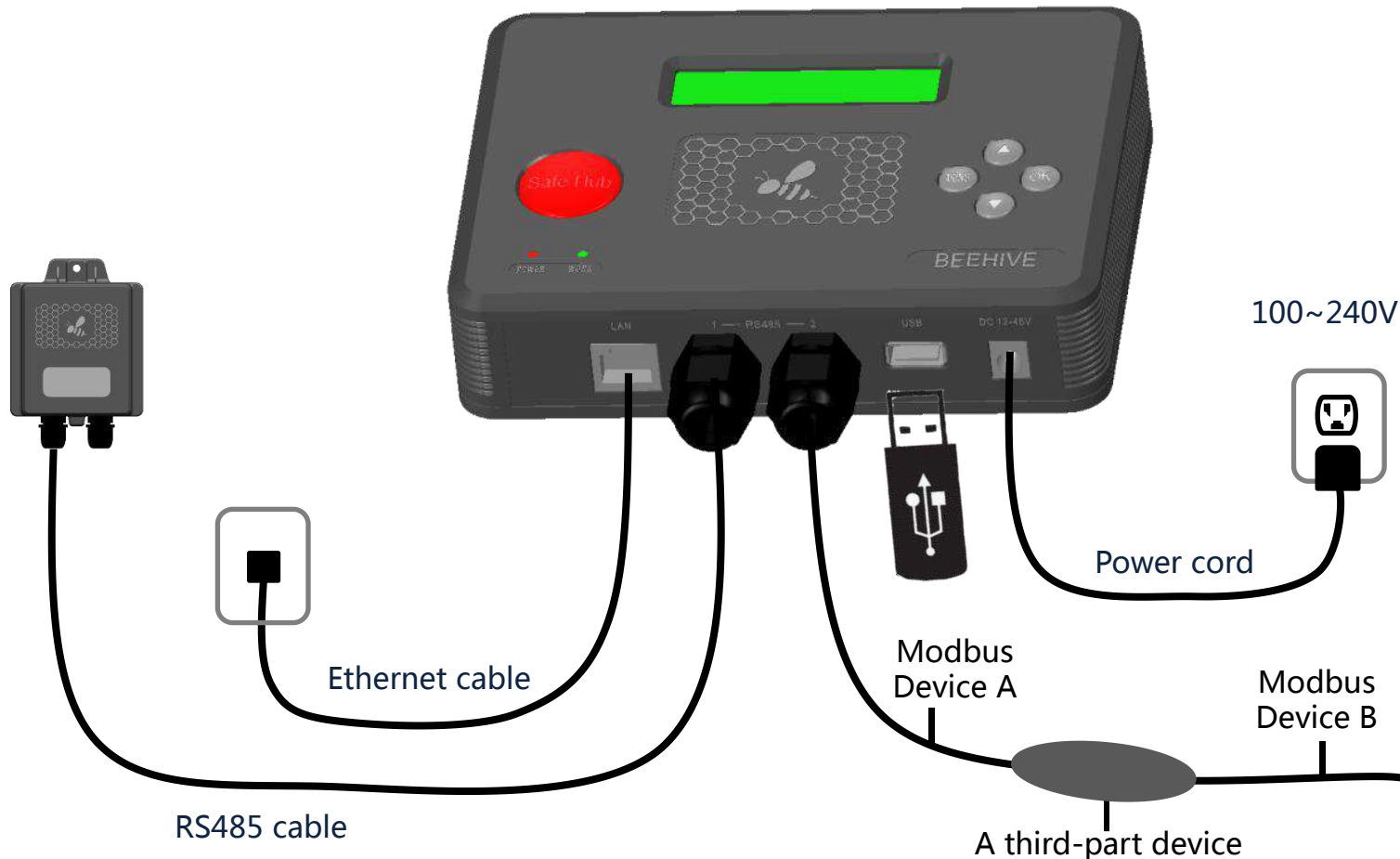

7. Setup in data cloud center (Honeypot)

Log in the GNE homepage: <http://gne.gnetek.com>, click on the monitoring center in the upper right corner

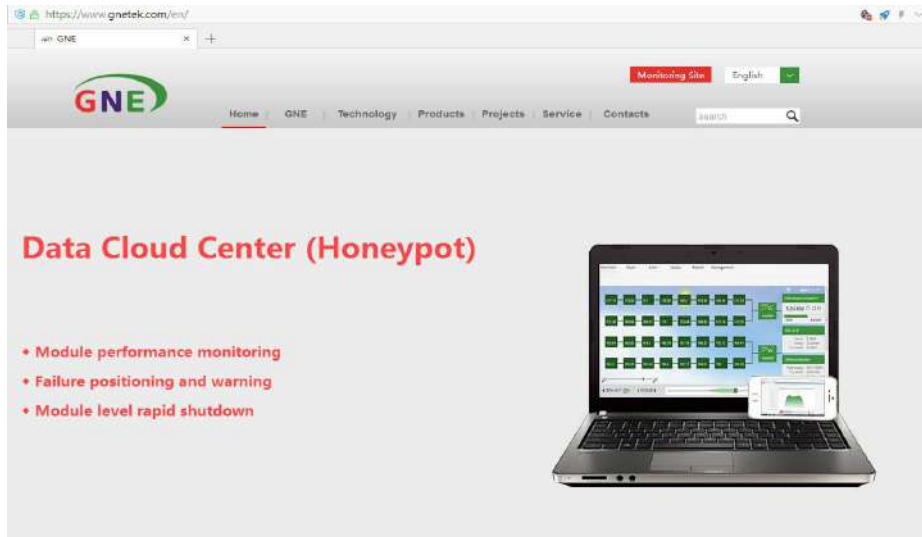

① New Account Register



New account Register

② Fill in the information of the new account

The screenshot shows the "Register" form on the GNE website. The header includes the GNE logo and "Jiangsu GNE New Energy Technology Co., Ltd." with an "English" language selector. The form title is "Register" with a note: "Note: This page is for new user to create account." The form contains the following fields: "*User Name:" (required), "*Confirm Password:" (required), "*Confirm Email:", "First Name:", "PostCode:", "*Verification Code:" (with a captcha "xwx10"), "*Password:" (required), "*Email:", "Company:", "Street:", and "*TimeZone:" (dropdown menu with "UTC Western European Time, Green" selected). A "Submit" button is at the bottom right.

7. Setup in data cloud center (Honeypot)

③ Fill in the information of the inverter and the panel

Add more inverters or panels if needed

Station List Search the station

Plant User Administration

1 Station information 2 Inverter & Module 3 Data Devices 4 Station Setting 5 Layouts

Inverter

Inverter

*Label: is required *Manufacturer:

*Model: is required *Peak power(kW): is required

*Number of strings: is required *Modules per string: is required

Module

Module

*Manufacturer: *Model:

*Module power(W): is required

Save

④ Fill in the 8-digit of MACID of the Beehive

Station List Search the station

Plant User Administration

1 Station information 2 Inverter & Module 3 Data Devices 4 Station Setting 5 Layouts

Beehive Setting

*Unit Id: Device: OFF

Save

⑤ Select optimizer model, fill in 8 digits of MACID of the optimizers

Plant User Administration

1 Station information 2 Inverter & Module 3 Data Devices 4 Station Setting 5 Layouts

Mode A Mode B

Station Setting

Inverter-Growatt

String	Inverter-Growatt	MAC ID	MAC ID	Module	Module	Actions
Honeybee-700		60020885	-1	NSP(305W)		Delete Insert
Honeybee-700		60020885	-2	NSP(305W)		
Honeybee-700		60021770	-1	NSP(305W)		Delete Insert
Honeybee-700		60021770	-2	NSP(305W)		
Honeybee-700		60020951	-1	NSP(305W)		Delete Insert
Honeybee-700		60020951	-2	NSP(305W)		
Honeybee-700		60021700	-1	NSP(305W)		Delete Insert

7. Setup in data cloud center (Honeyplot)

⑥ Adjust the location of the optimizers per the physical layout of the PV station

The screenshot displays the software interface for managing a PV station. The top header shows the company name 'Jiangsu GNE New Energy Technology Co., Ltd.' and the user 'J.Brugman'. The main navigation bar includes 'Station List', 'Plant', 'User', and 'Administration'. A progress bar indicates the current step is '5. Layouts'. The main workspace features a grid with a transformer icon and several green boxes representing components, including a 'Growatt 36000TL-S' inverter and modules labeled A1 through A12 with their respective IDs. A 'Page Setup' dialog box is open on the right, showing settings for 'Background', 'Width' (800), and 'Height' (600).

Appendix - Product Specification

SPECIFICATION		MODEL				
		Honeybee350	Honeybee700	Honeybee400	Honeybee800	Scouter450
INPUT	Max. Input Power	350 W	350*2 W	450 W	450*2 W	450W
	Max. Input Voltage	60 Vdc		75 Vdc		75 Vdc
	Min.Module MPPT Voltage	16 Vdc		12 Vdc		-
	Max. Input Current	10 Adc		13 Adc		13 Adc
	Short Circuit Current	15 Adc				
OUTPUT	Output Power Range	0~350 W	0~350*2 W	0~450 W	0~450*2 W	0~450W
	Max Output Current	11 Adc		13 Adc		13 Adc
	Output Voltage Range	0 ~ Voc				
	Max System Voltage	1000 Vdc		1500 Vdc		1500 Vdc
EFFICIENCY	Max. Converter Efficiency	99.50%	99.60%	99.60%	99.60%	99.90%
INSTALLATION SPECIFICATION	Size (L*W*T, mm)	127.5*106*22	130.5*129*25	130.3*109.6*25	130*132*24.5	127.5x106x22
	Weight	530 g	810 g	588 g	765 g	400g
	Input Linker	MC4		MC4		MC4
	Output Linker	MC4		MC4		MC4
	Working Temperature	-40 ~ +85 °C				
	Inbreaking Protection	IP65		IP67		IP67
	Relative Humidity	0~100%				
STANDARD COMPLIANCE	EMC	7IEC61000-6-2, IEC61000-6-37				
	Safety Regulations	IEC62109-1 (Class II safety)				
	Overvoltage Category	III				
	Certificate	CQC/TUV/CSA		CE		-